



SCOTT

RANSOM

2024

SCOTT RANSOM

—

TECH AND FACTS REPORT

INTRODUCING THE ALL-NEW RANSOM

OUR LATEST VERSION OF RANSOM HAS BEEN UNCOMPROMISINGLY ENGINEERED FOR MAXIMUM DOWNHILL PERFORMANCE AND AN ALL-TIME CONFIDENCE INSPIRING RIDE. KILLER GEOMETRY PAIRED WITH A SUPERNATURAL SUSPENSION KINEMATIC RESULT IN A BIKE THAT DOESN'T TAKE "NO" FOR AN ANSWER. DON'T HOLD YOURSELF HOSTAGE, RIDE RANSOM.



KEY TAKEAWAYS

CONFIDENCE INSPIRING

6-LINK KINEMATIC; SOLID DIRECT AND PRECISE FEEL TO THE CHASSIS; LOW CENTER OF GRAVITY; SHOCK BEARINGS ON ALL MODELS PROTECTED FROM THE ELEMENTS

VERSATILE

EFFICIENT CLIMBER; INCREDIBLE DESCENDER; FLOAT X NUDE SUSPENSION PERFORMANCE

ADJUSTABLE

ADJUSTABLE GEO, 29"/MX AND HEADANGLE; COMPATIBLE WITH A WIDE RANGE OF SHOCKS; SYNCROS INTEGRATED MATCHBOX KIT

STRONG

METICULOUSLY ENGINEERED OPTIMAL STRENGTH



RANSOM

INTEGRATED SUSPENSION TECHNOLOGY **6-BAR LINKAGE**

Suspension characteristics were the key driver in the development of the all-new Ransom as we looked to maximize the bike's potential. At the core of the all-new Ransom sits a 6-bar linkage paired to our integrated suspension system, which provides us with the freedom to further refine suspension characteristics. With the Ransom's suspension layout, you get a great pedaling platform, incredible grip when braking and fantastic support when giving it the beans.



All suspension design is a game of balances. Traditionally there are trade-offs to be made between Leverage Ratio, Anti Squat and Anti Rise and how these affect the frame structure and frame layout itself. The 6-bar allows us to choose exactly how the suspension performs, providing us greater control to tune each parameter independently from each other resulting in fewer compromises and a better control of the balance. By looking at the bike as a system, this flexibility allows us to engineer this sweet spot between suspension performance, efficient load transfer and an optimized frame layout.



Looking at the 2024 Ransom lineup, the platform features our NUDE Suspension technology with the Float-X NUDE shock from FOX custom tuned for the Ransom's kinematic and paired with bearing hardware. When you pedal up to have the most fun on the way down, you want a shock that gives you full factory performance when things point downwards, but also a shock that won't slow you down when you need to ride back up. This is where the Float-X NUDE shines.

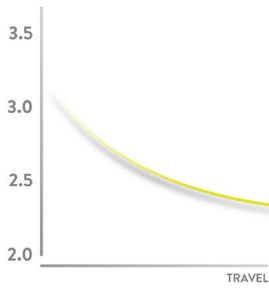

Leverage Ratio (LR) - A progressive LR curve gives great initial sensitivity with mid-stroke support

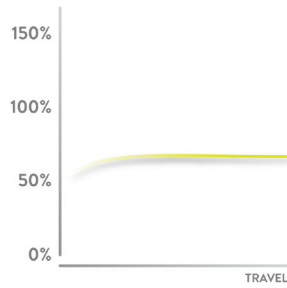

Anti Rise (AR) - Predictable suspension behavior while breaking

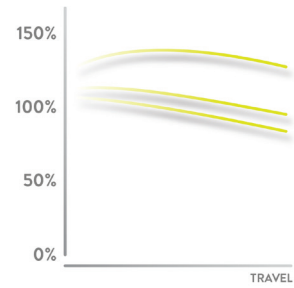

Anti Squat (AS) - Efficient pedaling while keeping pedal kickback low

Furthermore, the new Ransom is fully compatible with a wide range of coil and air shocks which are aligned inside the downtube giving a super low center of gravity, particularly important for the enduro segment where larger, heavier shocks are common.

COMPATIBLE SHOCK OPTIONS

FOX	FLOAT X, FLOAT X2, DHX, DHX2
ROCKSHOX	SUPERDELUXE AIR
OHLINS	TTX22 COIL, TTX2 AIR
MARZOCCHI	BOMBER AIR & COIL



FRAME CONSTRUCTION

Developed as a bike for demanding gravity use, the Ransom's frame layout features meticulously engineered structural strength. The central Bottom-Bracket area is inherently one of the stiffest areas of each frame on which the highest forces and loads act. Centering kinematic and suspension here allows us to use the area's further reinforced structure for double duty; reacting to both pedaling loads and suspension loads. Being able to spread load transfer in each frame element evenly provides the Ransom with its natural strength, without the need to reinforce or oversize tubes.



VERSATILITY

As today's requirements are so versatile and riding preferences differ from rider to rider, adjustability became an essential part of a bike's development process to ensure the ride experience can be adapted according to personal preferences or different racetrack conditions.

As is the case with many of our mountain bikes, head tube angle is adjustable. This allows for adapting to terrain and riding style. Choose between a steeper setup for increased responsiveness at lower speeds and maneuverability through slower, tighter, and more technical terrain, and a slacker angle for stability descending at higher speeds and confidence in steep terrain. The bike comes with headset cups that allow you to choose between a 65.0- or 63.8-degree head angle. All models are also shipped with additional neutral headset cups allowing for a 64.4-degree head tube angle.



Featuring 29" wheels as standard, the Ransom can be ridden with a 27.5" rear wheel setup. Easily customized by using a simple flip chip, the bike is ready for 27.5" wheels in the rear depending on each rider's preference.

The horizontal shock position makes for easy shock access and allows us to spec even longer dropper posts (180mm on size medium.)



DROPPER POST INSERTION

DROPPER POST HEIGHT CALCULATOR

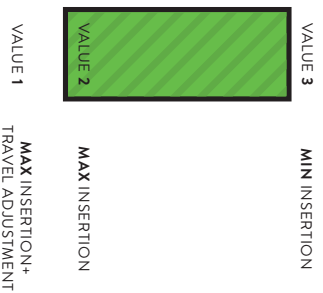

syncros

FOX

ROCK SHOX

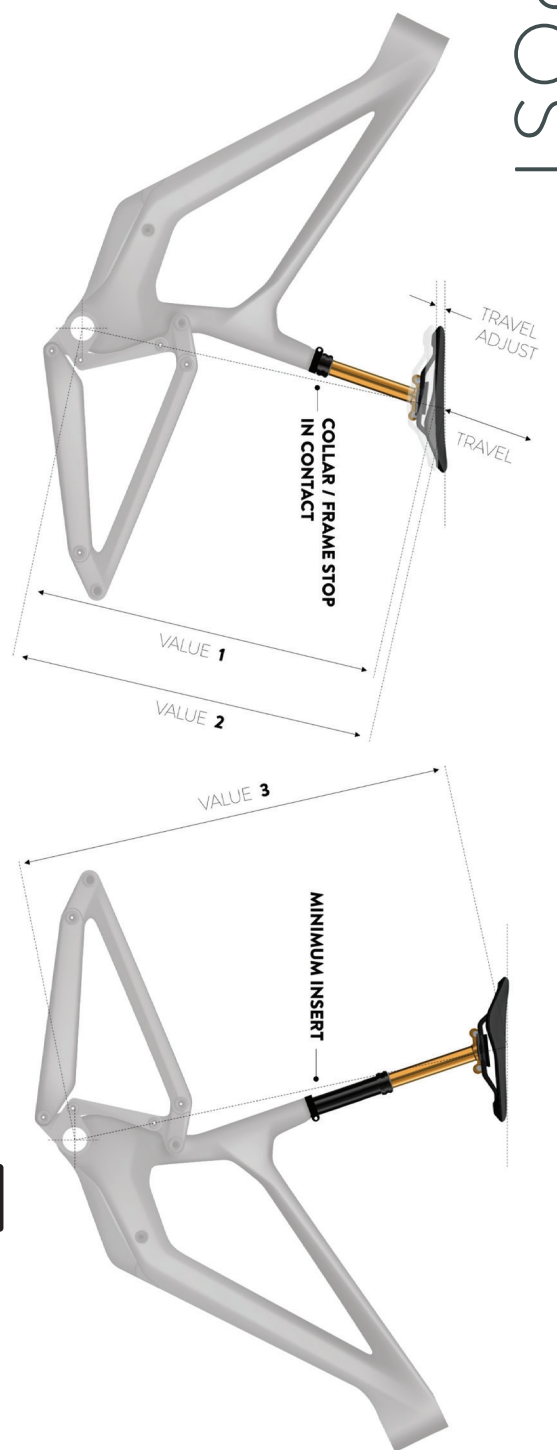

			716 622			597
S	YSL-35	140L				
M	YSL-35	180L	796 702	677		
L	YSL-35	210L	857 762	738		
XL	YSL-35	210L	887 763	738		

			735 651			
S	Fox Transfer	MV21 150L				
M	Fox Transfer	MV21 175L	822 708	708		
L	Fox Transfer	MV21 200L	859 764	764		
XL	Fox Transfer	MV21 200L	889 765	765		

			777 672			
S	Rock Shox	Reverb AXS				
M	Rock Shox	Reverb AXS	847 713	713		
L	Rock Shox	Reverb AXS	878 714	714		
XL	Rock Shox	Reverb AXS	908 744	744		



DEVIL IN THE DETAILS

But that's not all by a long shot. The clever integration of features into the overall concept provides the decisive advantage in the performance battle for seconds on the racetrack or chasing dream laps in the bikepark with your friends.



1

SETTING SAG

> Setting sag and checking travel use is easier than ever before with the new Ransom. An external indicator on the link allows the end user to easily set themselves. No need to take out ruler to calculate sag, just sit on the bike as you would for a normal sag test and check what the dial says.

2

SHOCK ACCESS

> Accessing the integrated shock is just a button away. The downtube cover that is featured on all Ransom models provides access and protection in the same way. The cover is easily removable - just push the button, pop off the cover and shock access is granted. The opening is spacious, making everything maintenance related and cable routing much easier. The same applies for removing the shock itself. A window on the main part of the frame gives direct access to the shock bolt holding the shock in its position.

3

INTERNAL STORAGE

> The easy access to the inner frame frees further possibilities: Fully integrated in the down tube is the Syncros Matchbox Kit, which contains a Spare tube, Tire levers, Chain Tool and Multitool; This very clean and functional solution is easy to pull out and stow again ensuring one always has the necessary items in case of a trail side mechanical.

GEOMETRY

We've dialed in the new Ransom's geometry combining various aspects for a confidence inspiring ride in the roughest and fastest DH sections, but without compromising the bike's agility and precision when needed in tight corners and technical terrain.

FRAME SIZE MEDIUM

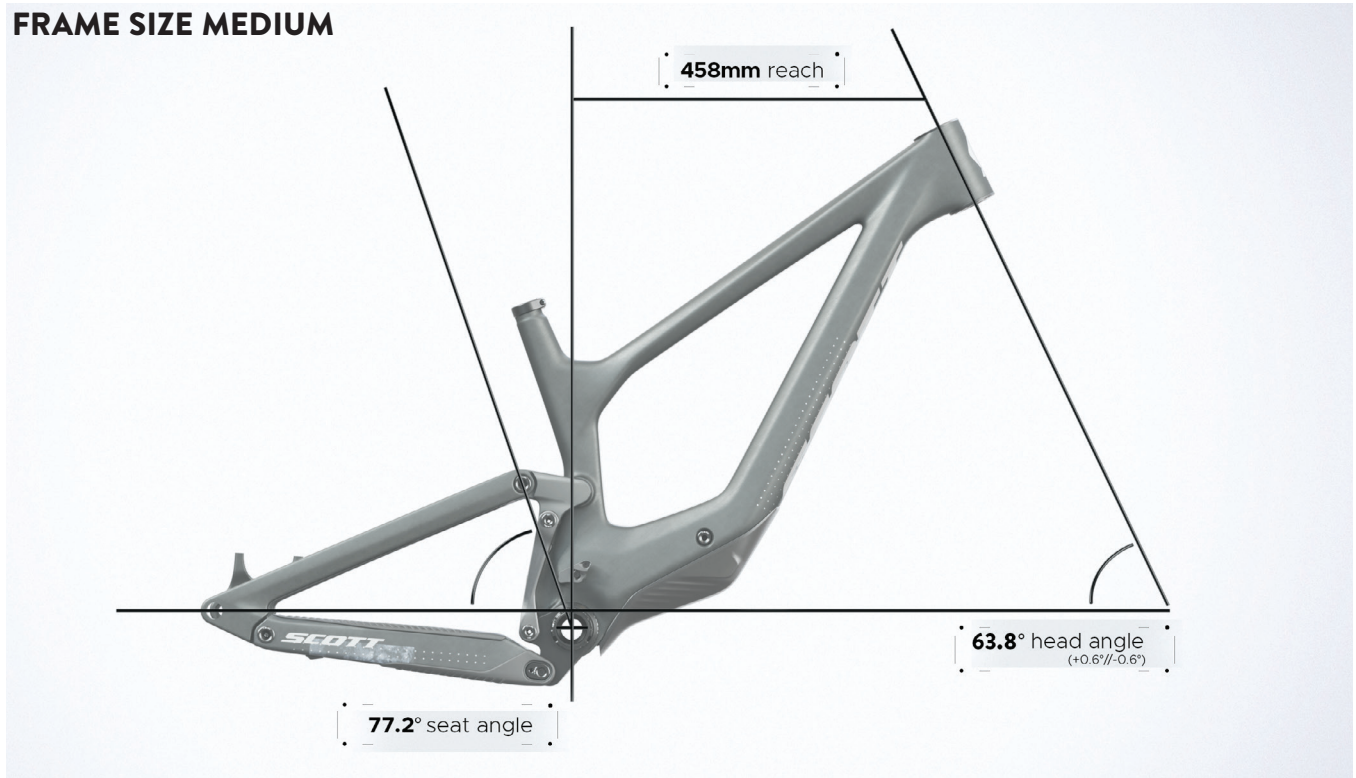

		S		M		L		XL	
A	HEAD TUBE ANGLE (-0.6° HEADSET SETTING)	63.8°		63.8°		63.8°		63.8°	
B	HEAD TUBE LENGTH	95,0 MM	3,7 IN	100,0 MM	3,9 IN	115,0 MM	4,5 IN	125,0 MM	4,9 IN
C	TOP TUBE HORIZONTAL	569,9 MM	22,4 IN	598,7 MM	23,6 IN	624,4 MM	24,6 IN	649,1 MM	25,6 IN
D	STANDOVER HEIGHT	719,2 MM	28,3 IN	725,4 MM	28,6 IN	736,7 MM	29,0 IN	755,3 MM	29,7 IN
E	BB OFFSET	-25,0 MM	-1,0 IN	-25,0 MM	-1,0 IN	-25,0 MM	-1,0 IN	-25,0 MM	-1,0 IN
F	BB HEIGHT	350,0 MM	13,8 IN	350,0 MM	13,8 IN	350,0 MM	13,8 IN	350,0 MM	13,8 IN
G	WHEEL BASE	1,206,6 MM	47,5 IN	1,238,8 MM	48,8 IN	1,270,4 MM	50,0 IN	1,299,8 MM	51,2 IN
H	BB CENTER TO TOPTUBE CENTER								
I	BB CENTER TO TOP OF SEATTUBE	380,0 MM	15,0 IN	410,0 MM	16,1 IN	440,0 MM	17,3 IN	470,0 MM	18,5 IN
J	SEAT ANGLE	77,0°		77,2°		77,4°		77,6°	
K	CHAINSTAY	440,0 MM	17,3 IN	440,0 MM	17,3 IN	440,0 MM	17,3 IN	440,0 MM	17,3 IN
L	REACH	428,0 MM	16,9 IN	458,0 MM	18,0 IN	483,0 MM	19,0 IN	508,0 MM	20,0 IN
M	STACK	614,8 MM	24,2 IN	619,3 MM	24,4 IN	632,8 MM	24,9 IN	641,7 MM	25,3 IN
N	STEM LENGTH	40,0 MM	1,6 IN	40,0 MM	1,6 IN	40,0 MM	1,6 IN	40,0 MM	1,6 IN
O	TRAIL	135,5 MM	5,3 IN	135,5 MM	5,3 IN	135,5 MM	5,3 IN	135,5 MM	5,3 IN
P	FORK LENGTH	581,0 MM	22,9 IN	581,0 MM	22,9 IN	581,0 MM	22,9 IN	581,0 MM	22,9 IN
Q	MAXIMUM SEATPOST INSERTION	184,5 MM	7,3 IN	214,6 MM	8,4 IN	244,7 MM	9,6 IN	274,6 MM	10,8 IN
R	CRANK LENGTH	170,0 MM	6,5 IN	170,0 MM	6,7 IN	170,0 MM	6,7 IN	170,0 MM	6,7 IN





RANSOM LINEUP

RANSOM 900 RC

293024

29

S, M, L, XL



WHAT'S NEW

Fox Float X Nude with Bearing Hardware, SRAM Transmission, SRAM Code 4 Piston Brakes, Syncros Travel Adjust Dropper, Syncros Tubeless Handlebar Tool, Syncros Matchbox Integrated Storage

<p>FRAME Ransom Carbon HMX, Integrated Suspension Technology, 6 Link kinematic / Adjustable head angle, Syncros Cable Integration System, BB92 / UDH Interface / 12x148mm with 55mm Chainline / MX Ready</p> <p>FORK FOX 38 Float Factory Grip 2 Air / Kashima, HSC - LSC - HSR - LSR adjustable / Kabolt: 15x110mm axle, 44mm offset / tapered steerer, Climb - 130 - 170mm</p> <p>REAR SHOCK FOX FLOAT X NUDE Factory EVOL Piggy Back Trunnion, Kashima / SCOTT custom w. travel / geo adj., 3 modes: Climb-Ramp Control-Descend, Custom large Air volume / Comp & Reb. Adj., Travel 170-130-Climb / T205x65mm / Bearing Hardware</p> <p>REMOTE SYSTEM TracLoc Technology, Rear Suspension & Dropper Remote, 3 Rear Suspension modes</p> <p>REAR DERAILLEUR SRAM XO Eagle AXS Transmission 12 Speed, Wireless Electronic Shift System</p>	<p>SHIFTERS SRAM AXS Rocker Controller</p> <p>CRANKSET SRAM XO Eagle Transmission, Bash guard / DUB / 55mm CL / 32T</p> <p>CHAINGUIDE SCOTT custom</p> <p>BB-SET SRAM DUB PF 92 MTB Wide / shell 41x92mm</p> <p>CHAIN SRAM CN XO Eagle Transmission</p> <p>CASSETTE SRAM XO Eagle XS 1295 Transmission 10-52</p> <p>BRAKES SRAM Code Ultimate Stealth 4 Piston Disc, SRAM HS2 Rotors F&R 200mm</p> <p>HANDLEBAR Syncros Hixon iC Carbon, Size S & M 15mm rise / Size L & XL 25mm rise, back sweep 8° / 780mm / 40mm, Syncros Endurance lock-on grips</p> <p>SEATPOST Syncros Duncan Dropper Post 1.5S / Travel Adjust / 31.6mm, S size 140mm / M size 180mm / L & XL size 210mm</p> <p>SEAT Syncros Tofino 1.5, Titanium Rails</p>	<p>HEADSET Syncros - Across Angle adjust & Cable Routing HS System, +0.6° head angle adjustment, Z556/28.6 - Z556/40 MTB</p> <p>WHEELSET Race Face Turbine R 30 / 110x15 / 148x12 rear / 29" / 28H / Tubeless Ready Rims / XD driver, Syncros Axle w/Removable Lever with Tool</p> <p>FRONT TIRES Maxxis Assegai / 2.5" / 60TPI Foldable / EXO+ / TR / 3C Maxx Gripp</p> <p>REAR TIRES Maxxis Dissector / 2.4" / 120TPI Foldable / DD / TR / 3C Maxx Terra</p> <p>EXTRAS SRAM AXS Powerpack, Syncros Trail Fender 2 36/38, Syncros Eco Sealant</p> <p>ACCESSORIES Syncros IS Matchbox kit, Syncros IS tubeless Handlebar tool / Syncros Multi-tool Matchbox 8</p> <p>APPROX. WEIGHT 15.2 KG (Tubeless setup without Matchbox IS), 33.51 LBS (Tubeless setup without Matchbox IS)</p>
--	--	---

RANSOM 910

293025

29

S, M, L, XL



WHAT'S NEW

Fox Float X Nude with Bearing Hardware, SRAM Transmission, SRAM Code 4 Piston Brakes, Syncros Travel Adjust Dropper, Syncros Tubeless Handlebar Tool, Syncros Matchbox Integrated Storage

<p>FRAME Ransom Carbon HMF Mainframe with Alloy 6061 Swingarm, Integrated Suspension Technology, 6 Link kinematic / Adjustable head angle, Syncros Cable Integration System, BB92 / UDH Interface / 12x148mm with 55mm Chainline / MX Ready</p> <p>FORK FOX 38 Float Performance Elite Grip 2 Air, HSC - LSC - HSR - LSR adjustable / Kabolt: 15x110mm axle, 44mm offset / tapered steerer, 170mm travel</p> <p>REAR SHOCK FOX FLOAT X NUDE EVOL Piggy Back Trunnion / SCOTT custom w. travel / geo adj., 3 modes: Climb-Ramp Control-Descend, Custom large Air volume / Comp & Reb. Adj., Travel 170-130-Climb / T205x65mm / Bearing Hardware</p> <p>REMOTE SYSTEM TracLoc Technology, Rear Suspension & Dropper Remote, 3 Rear Suspension modes</p> <p>REAR DERAILLEUR SRAM GX Eagle AXS Transmission 12 Speed, Wireless Electronic Shift System</p>	<p>SHIFTERS SRAM AXS Rocker Controller</p> <p>CRANKSET SRAM GX Eagle Transmission, Bash guard / DUB / 55mm CL / 32T</p> <p>CHAINGUIDE SCOTT custom</p> <p>BB-SET SRAM DUB PF 92 MTB Wide / shell 41x92mm</p> <p>CHAIN SRAM CN GX Eagle Transmission</p> <p>CASSETTE SRAM GX Eagle XS 1275 Transmission 10-52</p> <p>BRAKES SRAM Code RSC Stealth 4 Piston Disc, SRAM HS2 Rotors F&R 200mm</p> <p>HANDLEBAR Syncros Hixon iC Carbon, Size S & M 15mm rise / Size L & XL 25mm rise, back sweep 8° / 780mm / 40mm, Syncros Endurance lock-on grips</p> <p>SEATPOST Syncros Duncan Dropper Post 1.5S / Travel Adjust / 31.6mm, S size 140mm / M size 180mm / L & XL size 210mm</p>	<p>SEAT Syncros Tofino 1.5, Titanium Rails</p> <p>HEADSET Syncros - Across Angle adjust & Cable Routing HS System, +0.6° head angle adjustment, Z556/28.6 - Z556/40 MTB</p> <p>WHEELSET Syncros Revelstoke 2.0 6 Bolt, F: 15x110mm, R: 12x148mm Boost, 30mm Tubeless ready rim 28H / XD Driver, Syncros Axle w/Removable Lever with Tool</p> <p>FRONT TIRES Maxxis Assegai / 2.5" / 60TPI Foldable / EXO+ / TR / 3C Maxx Gripp</p> <p>REAR TIRES Maxxis Dissector / 2.4" / 120TPI Foldable / DD / TR / 3C Maxx Terra</p> <p>EXTRAS SRAM AXS Powerpack, Syncros Trail Fender 2 36/38</p> <p>ACCESSORIES Syncros IS Matchbox kit, Syncros IS tubeless Handlebar tool / Syncros Multi-tool Matchbox 8</p> <p>APPROX. WEIGHT 15.7 KG (Tubeless setup without Matchbox IS), 34.61 LBS (Tubeless setup without Matchbox IS)</p>
---	---	---

RANSOM 920

293026

29"

S, M, L, XL



WHAT'S NEW

Fox Float X Nude with Bearing Hardware, RS Zeb Select+ fork, Syncros Travel Adjust Dropper, Syncros Matchbox Integrated Storage

FRAME	Ransom Carbon HMF Mainframe with Alloy 6061 Swingarm, Integrated Suspension Technology, 6 Link kinematic / Adjustable head angle, Syncros Cable Integration System, BB92 / UDH Interface / 12x148mm with 55mm Chainline / MX Ready	CRANKSET	SRAM X1 1000 Eagle DUB Boost, 32T / Chainline 55mm	SEAT	Syncros Tofino 2.0, Crmo Rails
FORK	RockShox Zeb Select+ Charger 3, HSC - LSC - LSR adjustable / 15x110mm Maxle stealth axle, 42mm offset / Tapered Steerer, / 170mm travel	CHAINGUIDE	SCOTT custom	HEADSET	Syncros - Acros Angle adjust & Cable Routing HS System, +0.6° head angle adjustment, ZS56/28.6 - ZS56/40 MTB
REAR SHOCK	FOX FLOAT X NUDE EVOL Piggy Back Trunnion / SCOTT custom w. travel / geo adj., 3 modes: Climb-Ramp Control-Descend, Custom large Air volume / Comp & Reb. Adj., Travel 170-130-Climb / T205X65mm / Bearing Hardware	BB-SET	SRAM DUB PF integrated / shell 41x92mm	WHEELSET	Syncros Revelstoke 2.5 6 Bolt, F: 15x110mm, R: 12x148mm Boost, 30mm Tubeless ready rim 28Hr, Syncros Axle w/Removable Lever with Tool
REMOTE SYSTEM	TracLoc Technology, Rear Suspension & Dropper Remote, 3 Rear Suspension modes	CHAIN	SRAM CN SX Eagle	FRONT TIRES	Maxxis Assegai / 2.5" / 60TPI Foldable / EXO+ / TR / 3C Maxx Gripp
REAR DERAILLEUR	SRAM NX Eagle 12 Speed	CASSETTE	SRAM NX / PG1210 / 11-50 T	REAR TIRES	Maxxis Dissector / 2.4" / 120TPI Foldable / DD / TR / 3C Maxx Terra
SHIFTERS	SRAM SX Eagle Trigger	BRAKES	SRAM DB8 4 Piston Disc, SRAM Centerline Rotors F&R 200mm	EXTRAS	RS Zeb Fender
		HANDLEBAR	Syncros Hixon 2.0 Alloy 6061 D.B., Size S & M 12mm Rise / Size L & XL 20mm Rise / back sweep 8° / 780mm, Syncros Endurance lock-on grips	ACCESSORIES	Syncros IS Matchbox Kit / Syncros Multi-tool Matchbox 8
		HANDLEBAR STEM	Syncros AM 2.0, Syncros Cable Integration System, 4° rise / 6061 Alloy / 31.8mm / 40mm	APPROX. WEIGHT	16.4 KG (Tubeless setup without Matchbox IS), 36.16 LBS (Tubeless setup without Matchbox IS)
		SEATPOST	Syncros Duncan Dropper Post 1.5S / Travel Adjust / 31.6mm, S size 140mm / M size 180mm / L & XL size 210mm		

RANSOM 930

293027

29"

S, M, L, XL



WHAT'S NEW

Fox Float X Nude with Bearing Hardware, Syncros Travel Adjust Dropper, Syncros Matchbox Integrated Storage

FRAME	Ransom Carbon HMF Mainframe with Alloy 6061 Swingarm, Integrated Suspension Technology, 6 Link kinematic / Adjustable head angle, Syncros Cable Integration System, BB92 / UDH Interface / 12x148mm with 55mm Chainline / MX Ready	CRANKSET	Shimano FC MT512, 32T / Chainline 55mm	SEAT	Syncros Tofino 2.0, Crmo Rails
FORK	RockShox Domain R Solo Air, 15x110mm Maxle stealth axle, 42mm offset / Tapered Steerer, Reb. Adj. / 170mm travel	CHAINGUIDE	SCOTT custom	HEADSET	Syncros - Acros Angle adjust & Cable Routing HS System, +0.6° head angle adjustment, ZS56/28.6 - ZS56/40 MTB
REAR SHOCK	FOX FLOAT X NUDE EVOL Piggy Back Trunnion / SCOTT custom w. travel / geo adj., 3 modes: Climb-Ramp Control-Descend, Custom large Air volume / Comp & Reb. Adj., Travel 170-130-Climb / T205X65mm / Bearing Hardware	BB-SET	Shimano BB-MT500-PA / shell 41x92mm	HUB (FRONT)	Formula CL 811 / 15x110mm
REMOTE SYSTEM	TracLoc Technology, Rear Suspension & Dropper Remote, 3 Rear Suspension modes	CHAIN	Shimano CN M6100	HUB (REAR)	Formula CL 148M / Boost 12x148mm / Micro Spline
REAR DERAILLEUR	Shimano Deore RD M6100 / 12 Speed	CASSETTE	Shimano Deore CS-M6100-12 / 10-51 T	SPOKES	Stainless Black 15G / 1.8mm
SHIFTERS	Shimano Deore SL-M6100-R / Rapidfire Plus	BRAKES	Shimano MT520 4 Piston Disc, Shimano SM-RT64 / centerlock / 203mm	RIMS	Syncros X-30S / 32H / 30mm / Sleeve Joint, Tubeless ready
		HANDLEBAR	Syncros Hixon 2.0 Alloy 6061 D.B., Size S & M 12mm Rise / Size L & XL 20mm Rise / back sweep 8° / 780mm, Syncros Endurance lock-on grips	FRONT TIRES	Maxxis Assegai / 2.5" / 60TPI Foldable, EXO / TR / Dual
		HANDLEBAR STEM	Syncros AM 2.0, Syncros Cable Integration System, 4° rise / 6061 Alloy / 31.8mm / 40mm	REAR TIRES	Maxxis Dissector / 2.4" / 120TPI Foldable / DD / TR / 3C Maxx Terra
		SEATPOST	Syncros Duncan Dropper Post 1.5S / Travel Adjust / 31.6mm, S size 140mm / M size 180mm / L & XL size 210mm	EXTRAS	RS Zeb Fender
				ACCESSORIES	Syncros IS Matchbox Kit / Syncros Multi-tool Matchbox 8
				APPROX. WEIGHT	16.7 KG (with tubes without Matchbox IS), 36.82 LBS (with tubes without Matchbox IS)

CONTESSA RANSOM 910

293141



29

S, M, L

WHAT'S NEW

NEW Model

FRAME Ransom Carbon HMF Mainframe with Alloy 6061 Swingarm, Integrated Suspension Technology, 6 Link kinematic / Adjustable head angle, Syncros Cable Integration System, BB92 / UDH Interface / 12x148mm with 55mm Chainline / Mullet Ready

FORK FOX 38 Float Performance Elite Grip 2 Air, HSC - LSC - HSR - LSR adjustable / Kabolt 15x110mm axle, 44mm offset / tapered steerer, 170mm travel

REAR SHOCK FOX FLOAT X NUDE EVOL Piggy Back Trunnion / SCOTT custom w. travel / geo adj., 3 modes: Climb-Ramp Control-Descend, Custom large Air volume / Comp & Reb. Adj., Travel 170-130-Climb / 1205x65mm / Bearing Hardware

REMOTE SYSTEM TracLoc Technology, Rear Suspension & Dropper Remote, 3 Rear Suspension modes

REAR DERAILLEUR SRAM GX Eagle Transmission 12 Speed, Wireless Electronic Shift System

SHIFTERS SRAM AXS Rocker Controller

CRANKSET SRAM GX Eagle AXS Transmission, Bash guard / DUB / 55mm CL / 32T

CHAINGUIDE SCOTT custom

BB-SET SRAM DUB PF 92 MTB Wide / shell 41x92mm

CHAIN SRAM CN GX Eagle Transmission

CASSETTE SRAM GX Eagle XS 1275 Transmission 10-52

BRAKES SRAM Code RSC Stealth 4 Piston Disc, SRAM HS2 Rotors F&R 200mm

HANDLEBAR Syncros Hixon iC Carbon, Size S & M 15mm rise / Size L & XL 25mm rise, back sweep 8° / 780mm / 40mm, Syncros Endurance lock-on grips

SEATPOST Syncros Duncan Dropper Post 1.5S / Travel Adjust / 31.6mm, S size 140mm / M size 180mm / L size 210mm

SEAT Syncros Savona 1.5, Titanium Rails

HEADSET Syncros - Acros Angle adjust & Cable Routing HS System, +0.6° head angle adjustment, ZS56/28.6 - ZS56/40 MTB

WHEELSET Syncros Revelstoke 2.0 6 Bolt, F: 15x110mm, R: 12x148mm Boost, 30mm Tubeless ready rim 28H / XD Driver, Syncros Axle w/Removable Lever with Tool

FRONT TIRES Maxxis Assegai / 2.5" / 60TPI Foldable / EXO+ / TR / 3C Maxx Gripp

REAR TIRES Maxxis Dissector / 2.4" / 120TPI Foldable / DD / TR / 3C Maxx Terra

EXTRAS SRAM AXS Powerpack, Syncros Trail Fender 2 36/38

ACCESSORIES Syncros IS Matchbox kit, Syncros IS tubeless Handlebar tool / Syncros Multi-tool Matchbox 8

APPROX. WEIGHT 15.7 KG, 34.61 LBS





TECH AND FACTS REPORT

2024 SCOTT RANSOM
© SCOTT SPORTS 2023 / 2024

CONTACT:
JULIAN LITTERST
julian.litterst@scott-sports.com
MTB MARKETING MANAGER

SCOTT-SPORTS.COM

